

3-29-06 *HL*

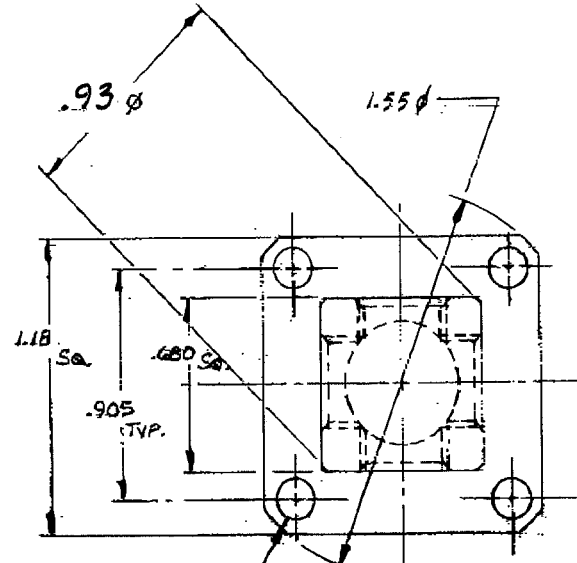
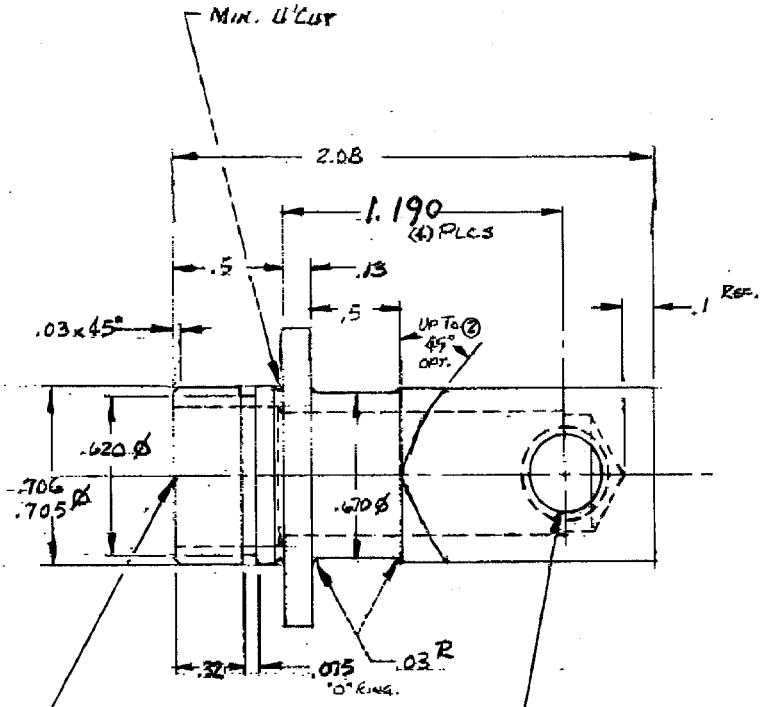

3 1/64 (.484) DIA. DRILL x 1.83 DEEP
 .501/.502 DIA x 1.7 DEEP
 C'DRILL .9/16 ϕ x .5 DEEP

3/8-40 UNEF. TAP THRU
 C'SINK .400 ϕ x 45° (FOR 'O' RING)
 (4) HOLES

.172 ϕ (4) HOLES
 ON 1.281 ϕ BOLT CIRCLE (REF.)
 AS SHOWN

1. BREAK ALL SHARP EDGES .005-.010
2. THIS CAN HAVE UP TO A 45° ANGLE CAUSED BY DIVEING A TURNING TOOL.

MATERIAL 303 STAINLESS

.X $\pm .030$
 .XX $\pm .015$
 .XXX $\pm .005$

TOOL EYE INC
 TOUCH MASTER
 MAZAK NEW STYLE
 911202

WAS 1.200 3-29-06 *HL*
 WAS .94 ϕ

150 Pa